

LGU35-P Series

UNIT TYPE

φ 35

0.8 Nm

Made-to-Order on Lot



EXAMPLE of STACKING

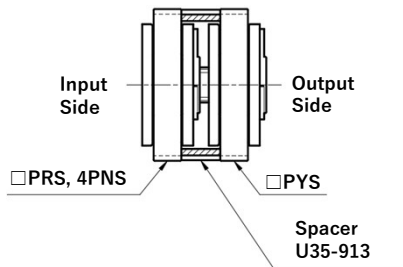

➤ See the Optional Parts Page

OUTPUT TORQUE CURVE

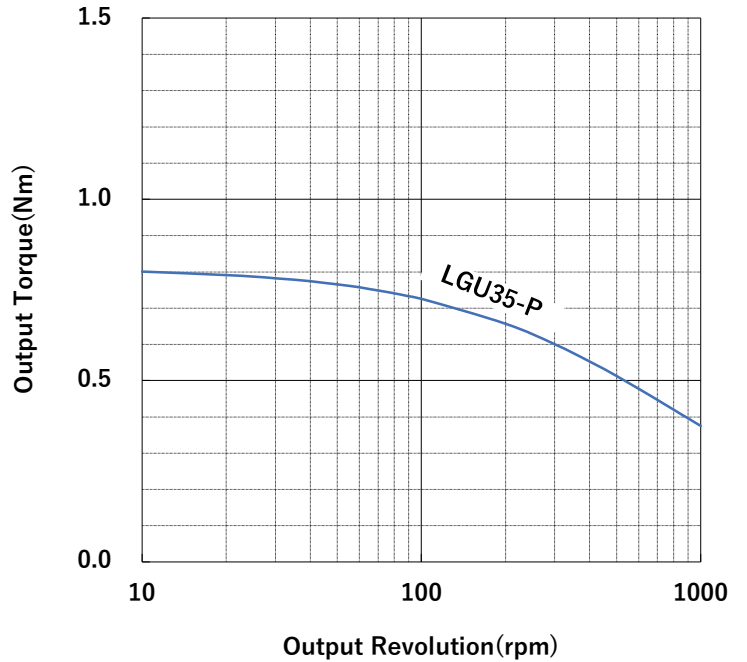

DIMENSIONS (mm)

LGU35-PRS,PNS

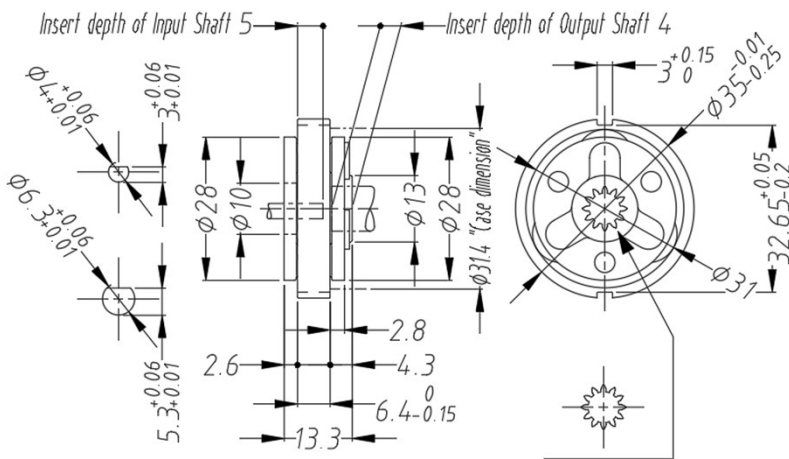

LGU35-PYS

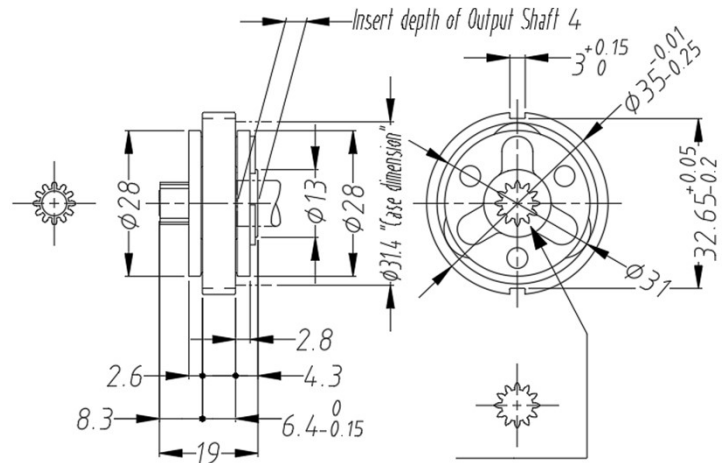

Series	Model Name	Actual Speed Ratio	Maximum Output Torque(Nm)	Input Shape	Output Shape	Weight (g)
LGU35-P	LGU35-4PRS	3.667	0.8	D Cut Hole φ4×3	Spur Gear Hole φ8.4×12z×0.6m	18
	LGU35-5PRS	5				19
	LGU35-4PNS	3.667		17		
	LGU35-4PYS	3.667		20		
	LGU35-5PYS	5		21		