

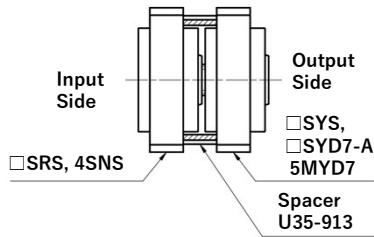

EXAMPLE of STACKING



- See the Multi-Stage Usage Page
- See the Optional Parts Page

OUTPUT TORQUE CURVE

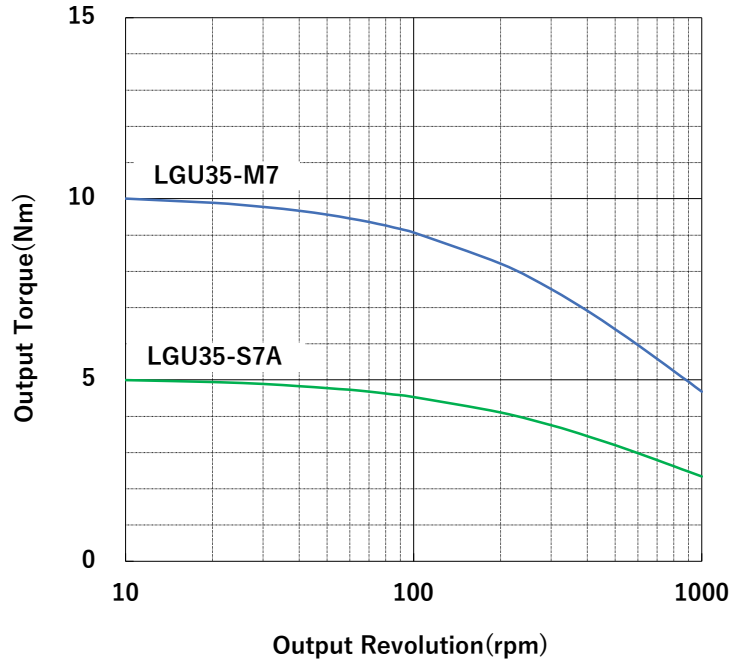

DIMENSIONS (mm)

LGU35-SYD7-A, 5MYD7

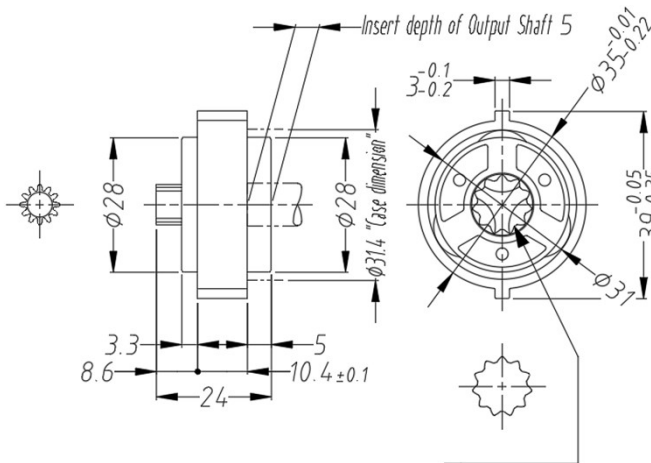

LGU35-4MLD7

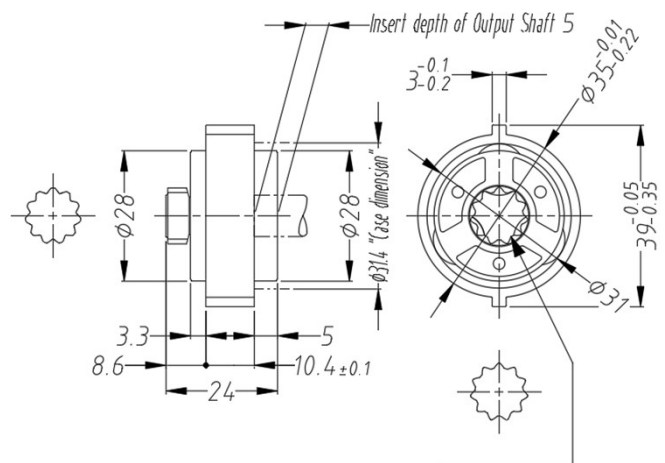

Series	Model Name	Actual Speed Ratio	Maximum Output Torque(Nm)	Input Shape	Output Shape	Weight (g)
LGU35-S7A	LGU35-4SYD7-A	3.667	5.0	Spur Gear Shaft φ8.4×12z×0.6m	Serration Hole 12×11×1	78
	LGU35-5SYD7-A	5				79
LGU35-M7	LGU35-4MLD7	3.667	10	Serration Shaft 12×11×1		83
	LGU35-5MYD7	5		Spur Gear Shaft φ8.4×12z×0.6m		81



※The units will not be stacked at shipment.

■ OUTPUT TORQUE CURVE

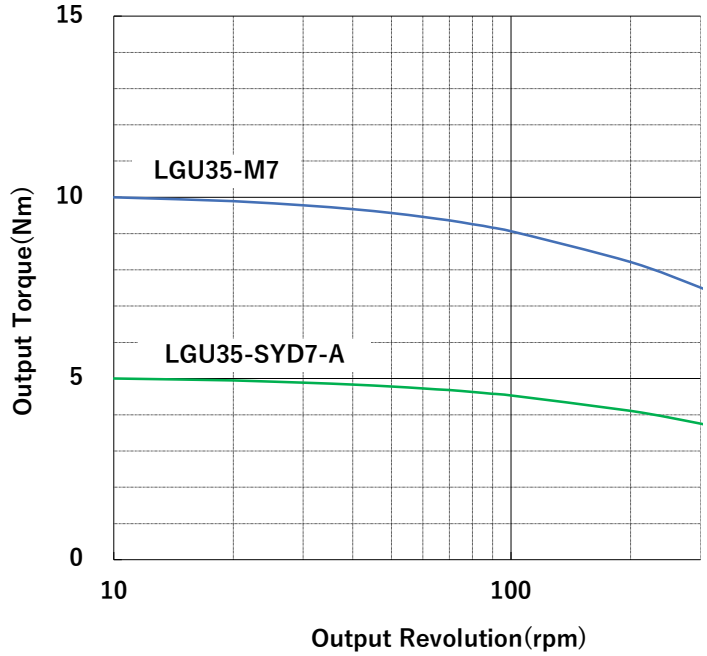

※The torque curve of the final stage (output side) is described.

■ DIMENSIONS (STACKED) (mm)

2 STAGES

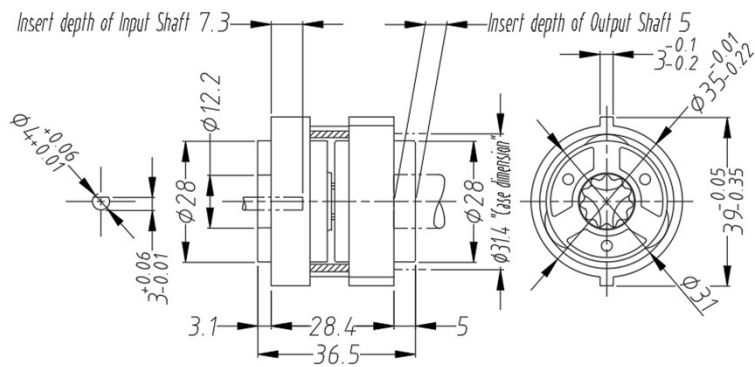

3 STAGES

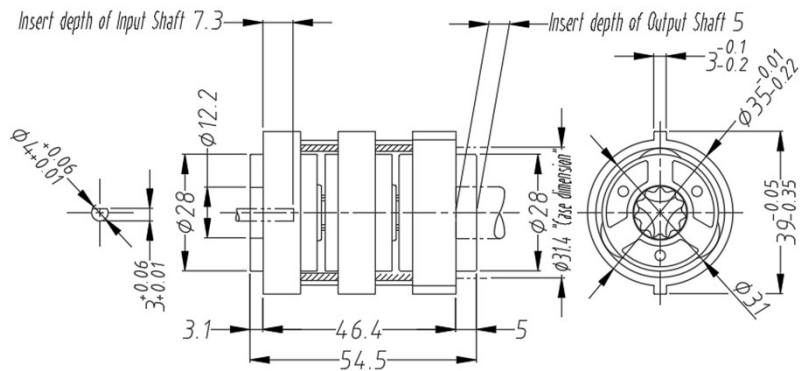

Actual Speed Ratio	1st Stage Model Name	2nd Stage Model Name	3rd Stage Model Name	Spacer (Option)	Maximum Output Torque(Nm)	Input Shape	Output Shape
13.4	LGU35-4SRS	LGU35-4SYD7-A	-	U35-913×1	5.0	D Cut Hole φ4×3	Serration Hole 12×11×1
18.3	LGU35-4SRS	LGU35-5SYD7-A			10		
		LGU35-5MYD7			5.0		
25	LGU35-5SRS	LGU35-5SYD7-A			10		
		LGU35-5MYD7	5.0				
49.3	LGU35-4SRS	LGU35-4SYS	LGU35-4SYD7-A	U35-913×2	5.0		
67.2	LGU35-4SRS	LGU35-4SYS	LGU35-5SYD7-A		10		
			LGU35-5MYD7		5.0		
91.7	LGU35-4SRS	LGU35-5SYS	LGU35-5SYD7-A		10		
125	LGU35-5SRS	LGU35-5SYS	LGU35-5SYD7-A	5.0			
			LGU35-5MYD7	10			