

LGU75-M12 Series

UNIT TYPE

φ 75

88 - 118 Nm



EXAMPLE of STACKING

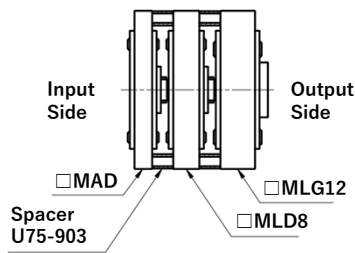

➤ See P32 for the Optional Parts

OUTPUT TORQUE CURVE

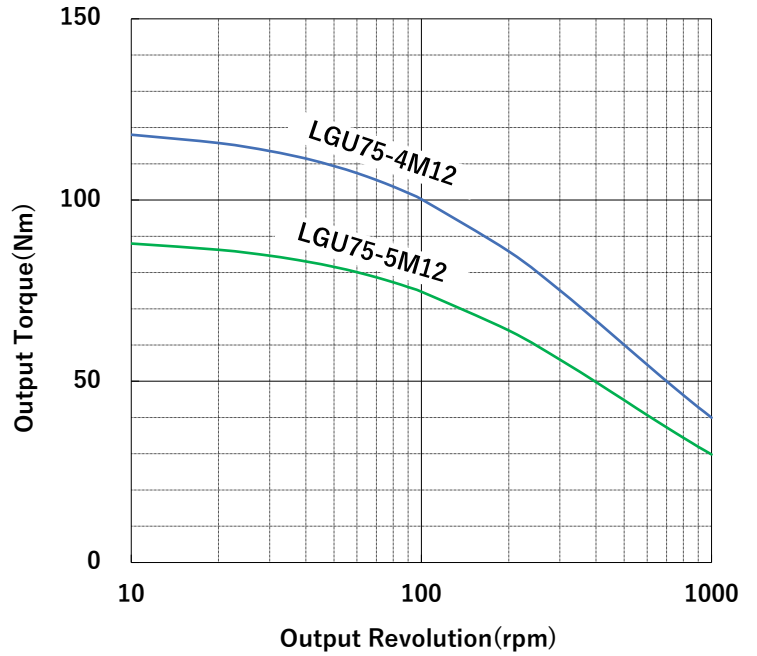

DIMENSIONS (mm)

LGU75-MDG12

LGU75-MLG12

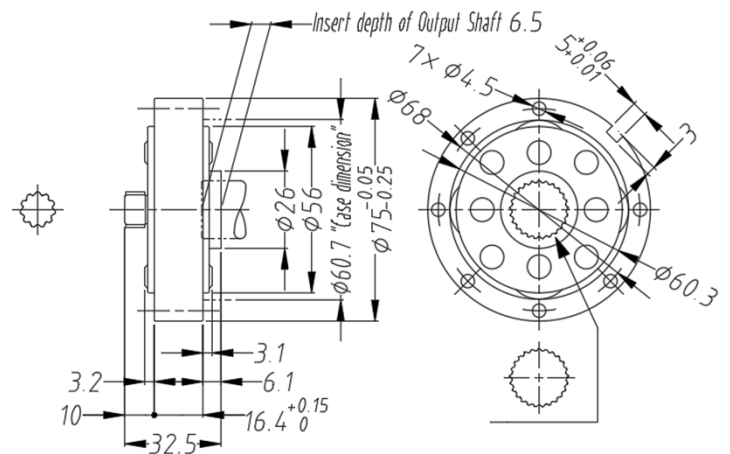
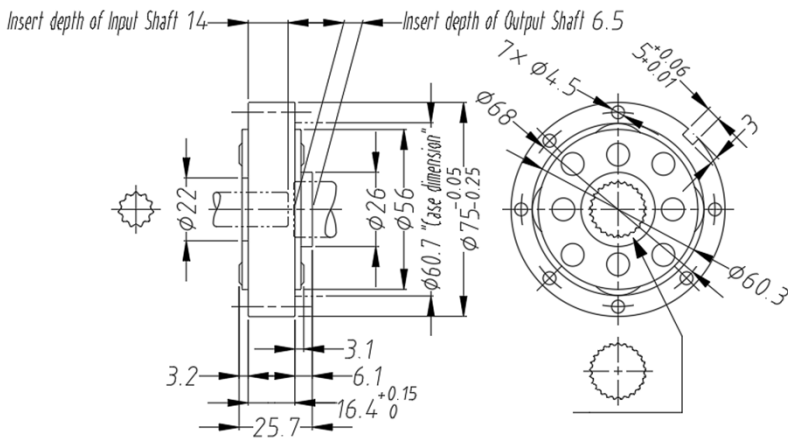

Series	Model Name	Actual Speed Ratio	Maximum Output Torque(Nm)	Input Shape	Output Shape	Weight (g)
LGU75-M12	LGU75-4MDG12	4	118	Serration Hole 12×11×1	Serration Hole 19.5×25×0.75	450
	LGU75-4MLG12			470		
	LGU75-5MLG12	5	88	Serration Shaft 12×11×1		430