

LGU75-P Series

UNIT TYPE $\phi 75$ 4.5 Nm

Made-to-Order on Lot



EXAMPLE of STACKING

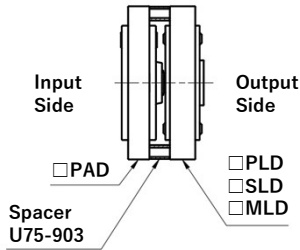

➤ See the Optional Parts Page

OUTPUT TORQUE CURVE

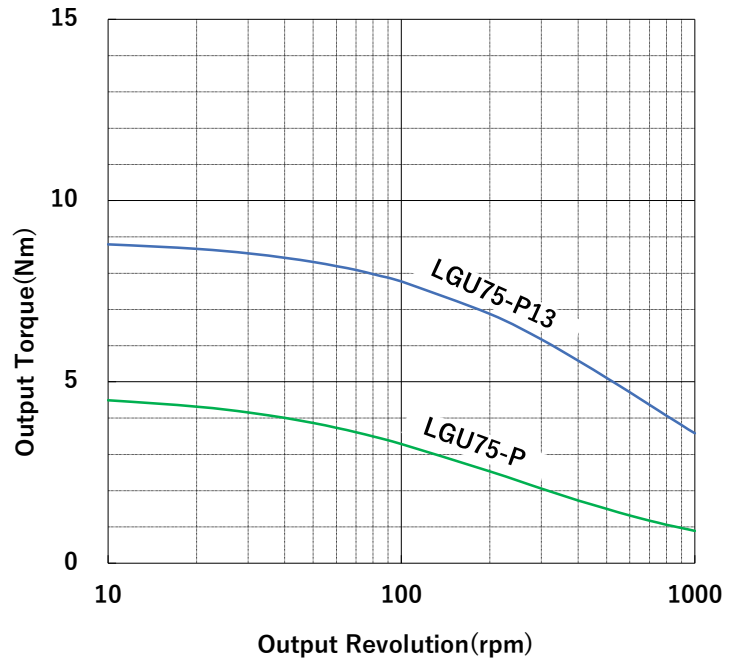

DIMENSIONS (mm)

LGU75-PAD

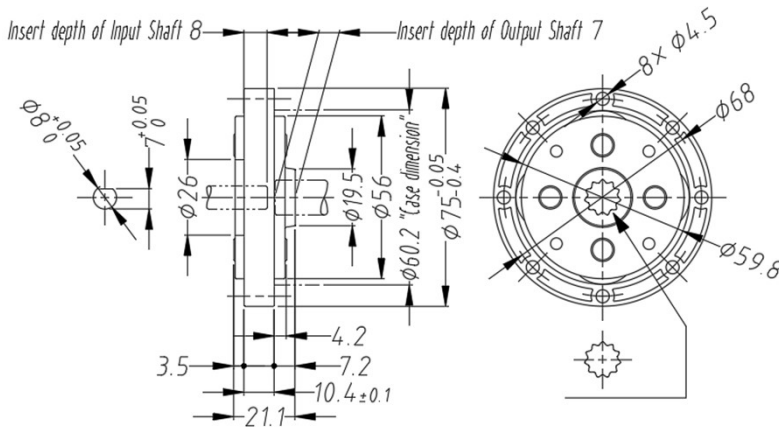

LGU75-PLD

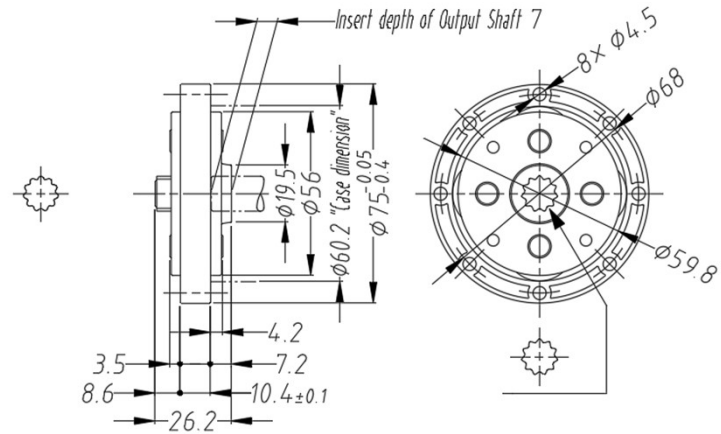

Series	Model Name	Actual Speed Ratio	Maximum Output Torque(Nm)	Input Shape	Output Shape	Weight (g)
LGU75-P	LGU75-3PAD	3.111	4.5	D Cut Hole φ8×7	Serration Hole 12×11×1	130
	LGU75-4PAD	3.714				130
	LGU75-5PAD	4.8				140
	LGU75-3PLD	3.111		Serration Shaft 12×11×1		130
	LGU75-4PLD	3.714				140
	LGU75-5PLD	4.8				150