

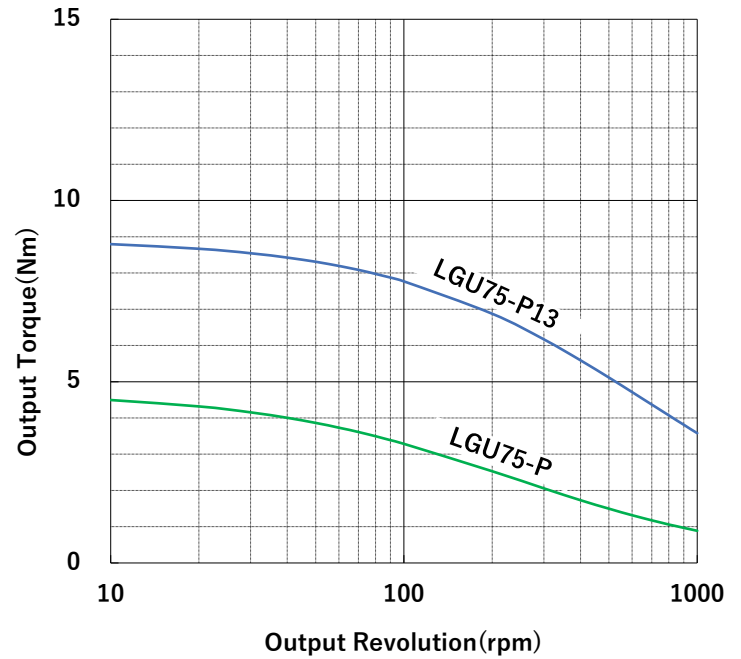

■ OUTPUT TORQUE CURVE

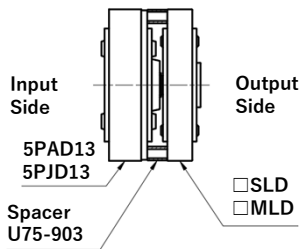

■ EXAMPLE of STACKING



➤ See P32 for the Optional Parts

■ DIMENSIONS (mm)

LGU75-5PAD13, 5PJD13

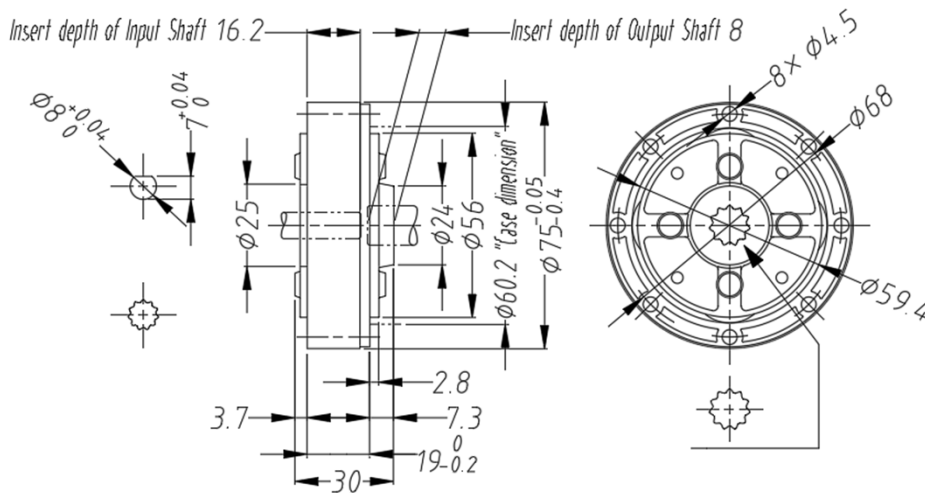

Series	Model Name	Actual Speed Ratio	Maximum Output Torque(Nm)	Input Shape	Output Shape	Weight (g)
LGU75-P13	LGU75-5PAD13	4.8	8.8	Serration Hole 9×11×0.75	Serration Hole 12×11×1	190
	LGU75-5PJD13	4.8				190