

LGU75-S Series

UNIT TYPE

φ75

8.0 - 12.4 Nm



EXAMPLE of STACKING

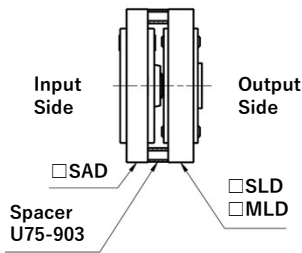

- See the Multi-Stage Usage Page
- See the Optional Parts Page

OUTPUT TORQUE CURVE

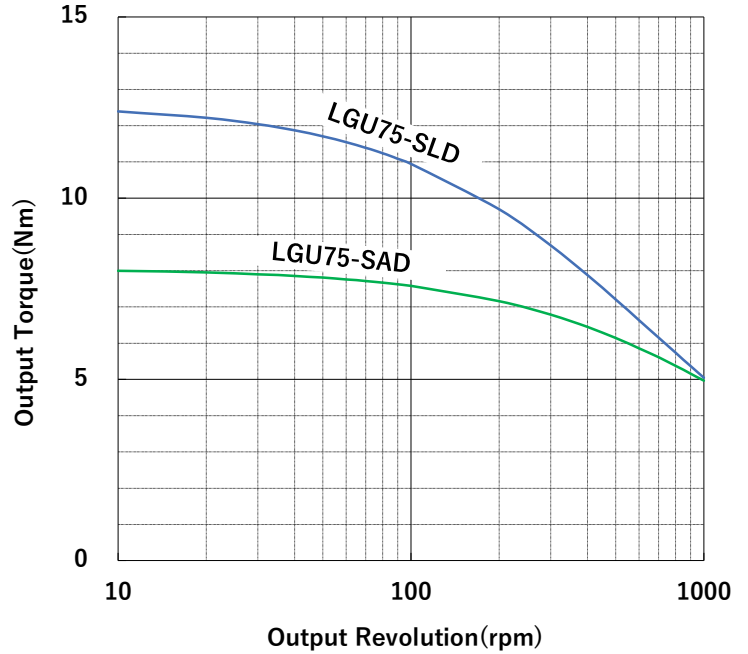

DIMENSIONS (mm)

LGU75-SAD

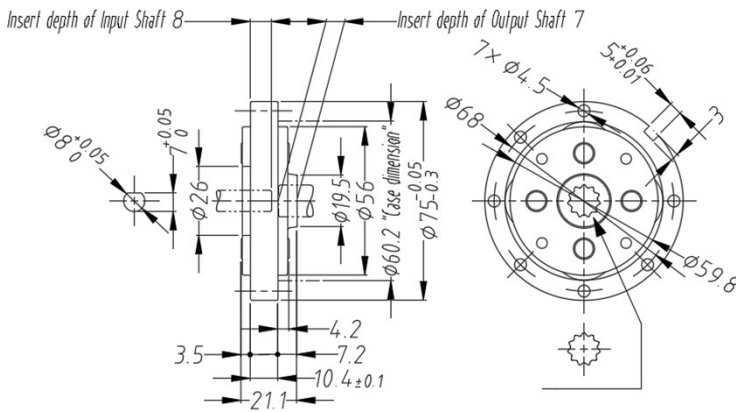

LGU75-SLD

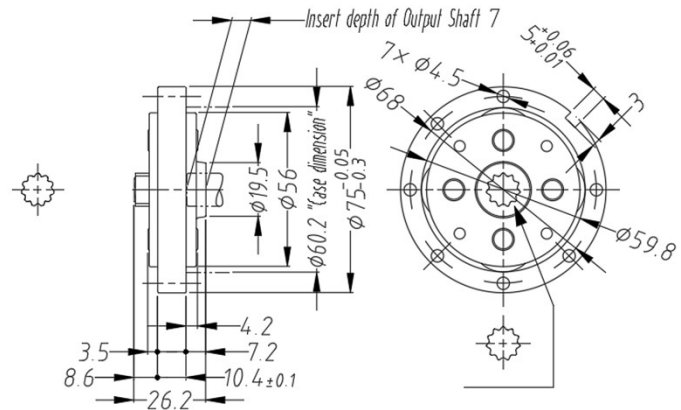

Series	Model Name	Actual Speed Ratio	Maximum Output Torque(Nm)	Input Shape	Output Shape	Weight (g)
LGU75-S	LGU75-3SAD	3.111	8.0	D Cut Hole φ8×7	Serration Hole 12×11×1	230
	LGU75-4SAD	3.714				240
	LGU75-5SAD	4.8				260
	LGU75-3SLD	3.111	12.4	Serration Shaft 12×11×1		240
	LGU75-4SLD	3.714				250
	LGU75-5SLD	4.8				260

LGU75 Multi-Stage UNIT TYPE COMBINATION $\phi 75$ 22.6 – 44.1 Nm



※The units will not be stacked at shipment.

OUTPUT TORQUE CURVE

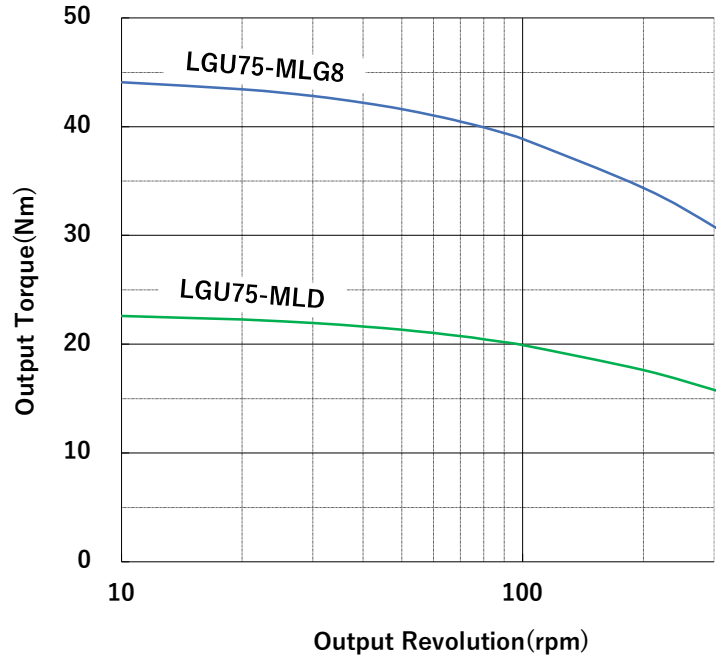

※The torque curve of the final stage (output side) is described.

DIMENSIONS (STACKED) (mm)

2 STAGES

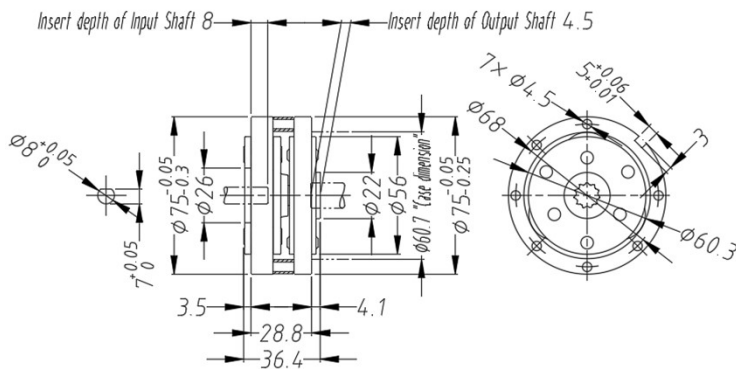

3 STAGES

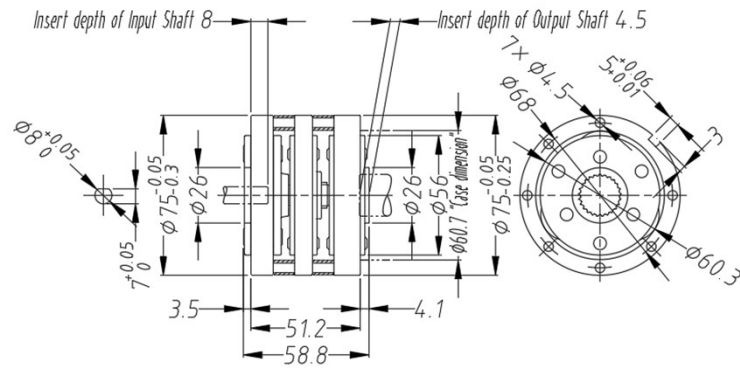

Actual Speed Ratio	1st Stage Model Name	2nd Stage Model Name	3rd Stage Model Name	Spacer (Option)	Maximum Output Torque(Nm)	Input Shape	Output Shape
9.33	LGU75-3SAD	LGU75-3MLD					
12.44	LGU75-3SAD	LGU75-4MLD					
14.86	LGU75-4SAD	LGU75-4MLD	-	U75-903×1	22.6		Serration Hole 12×11×1
18.57	LGU75-4SAD	LGU75-5MLD					
24	LGU75-5SAD	LGU75-5MLD					
44.57	LGU75-4SAD	LGU75-4MLD	LGU75-3MLG8			D Cut Hole $\phi 8 \times 7$	
59.42	LGU75-4SAD	LGU75-4MLD	LGU75-4MLG8				
74.28	LGU75-4SAD	LGU75-5MLD	LGU75-4MLG8	U75-903×2	44.1		Serration Hole 19.5×25×0.75
96	LGU75-5SAD	LGU75-5MLD	LGU75-4MLG8				
120	LGU75-5SAD	LGU75-5MLD	LGU75-5MLG8				